



**LAYERZERO**  
POWER SYSTEMS, INC.

The Foundation Layer

## Series 70: eSTS

4000 A 480 V 3-Pole Static Transfer Switch



Product Brochure

# The LayerZero eSTS Static Transfer Switch Maximizes Power Reliability

## eSTS Automatically Transfers Between Two or Three\* Power Sources

LayerZero Power Systems designs and manufactures the world's **most reliable** static transfer switch. The Series 70 eSTS is a solid-state transfer switch that automatically or manually provides solid state transfers between two in-phase AC sources in a quarter cycle. The eSTS performs open-transition transfer in such a manner that the connected load disruption is minimized without ever cross-connecting the power sources. One power source is selected to be the preferred source. If the preferred source fails the load is automatically and seamlessly connected to the alternate source by means of an open-transition static transfer. For emergency transfers between asynchronous sources, dynamically phase compensated transfers minimize saturation of downstream transformers in 3-phase, 3-wire eSTS.

\*Optional

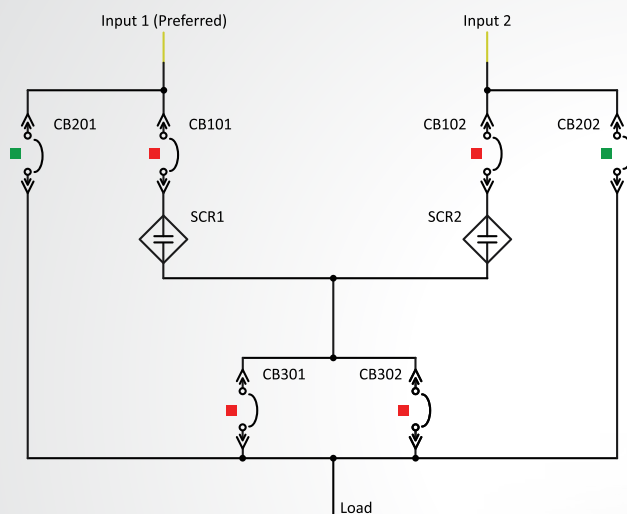

eSTS Static Transfer Switch One Line Diagram



Standard Features

Reliability



**Optional Triple Modular Redundancy:**  
TMR Contains Fully-Independent Control Paths With No Single Point-Of-Failure



**Safe Bypass Procedure:**  
Usage of Kirk Keys Eliminates Human Error When Performing Bypass Procedures



**Voice Guided Bypass:**  
Step-By-Step Instructions With Audio and Video Guidance To Assist Operators Through Bypass

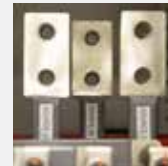

**Silver Plated Terminals:**  
Silver Has Excellent Conductivity To Provide Superior Electrical Performance and Reliability



**Maintenance-Free Joints:**  
Brazed Joints Are Permanent And Maintenance-Free, Maximizing Product Life



**Machined Hardware:**  
Machined Cap Screws and Engineered Disc Springs Maintain Constant Torque Throughout Product Life



**Optical Fiber Based Controls:**  
Eliminates Noise and Interference While Isolating Components from High Voltage



**Serialized Critical Board Tracking:**  
Critical Boards Are Serialized And Cataloged in an Active Database For Traceability

Safety



**INSIGHT IR® Cameras:**  
Built-in Infrared Cameras to Continuously Scan Bolted Connections For Irregular Rises In Temperature



**Sectionalized Components:**  
Isolated Sections That Can Be Safely De-Energized For Performing Maintenance



**Polycarbonate Windows:**  
Allows Critical Board LEDs To Be Viewed With The Dead-Front Door Closed



**Front and Rear Access:**  
Installation and Maintenance Can Be Safely Performed with only Front and Rear Access



**Dead Front Hinged Doors:**  
Barrier To Provide A Safe Working Area With No Exposed Live Parts

Connectivity

**Ethernet Connectivity:**  
Secure VPN Router Connects To Network For Advanced Remote Monitoring Capabilities

**Modbus/TCP:**  
Open Connectivity to Existing Monitoring Systems Without Proprietary Limitations

**NTP Time Clock Synchronization:**  
Facilitates Timeline-Based Logging For Post-Event Reconstruction

**SNMP Connectivity:**  
Permits Remote Management Via Simple Network Management Protocol

Power Quality Monitoring

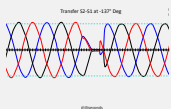

**Real-Time Waveform Capture:**  
Automatically Captures A Picture Of The Power Three-Cycles Before and After Every Event

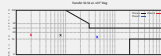

**ITIC Plotting:**  
Generate ITIC Plots To Determine if Connected Equipment Was Affected by Power Quality Events



**Local Touch-Screen Interface:**  
Password-Protected Color Touch-Screen GUI For Local STS Setup/Operation/ Administration



**Waveforms Automatically Emailed:**  
Capability to Send Waveform Captures To Designated Individuals For Every Transfer

Generate Easy-To-Understand Power Quality Reports with ITIC Plotting

All LayerZero Power Systems products have on-board power quality analyzers that break down power sources into samples. If the power quality goes out of specification on a source, eSTS will transfer to the alternate source, automatically generating waveform captures and VDAT-generated ITIC curves of the event. This data is remotely accessible by connecting to the unit via web browser.

VDAT (Voltage Disruption Analysis Tool) is a quantum leap in the field of power systems data interpretation. By harnessing state-of-the-art algorithms and processing techniques, VDAT effortlessly translates complex power data into discernible, actionable insights. VDAT tackles a major industry challenge: while traditional waveform captures are often intricate and challenging to interpret, VDAT brings clarity with its intuitively designed plots based on Information Technology Industry Council (ITIC) standards, empowering professionals to make quick and informed decisions.

In the test below, the STS was connected to two sources 150 degrees out-of-phase. Source 2 breaker was opened, causing the STS to perform an automatic transfer to the primary source. A delayed transfer occurred, causing events on Phases A, B, and C, automatically generating ITIC plots. Unlike waveform captures, ITIC plots are easy-to-read, and do not require expert analysis to understand.

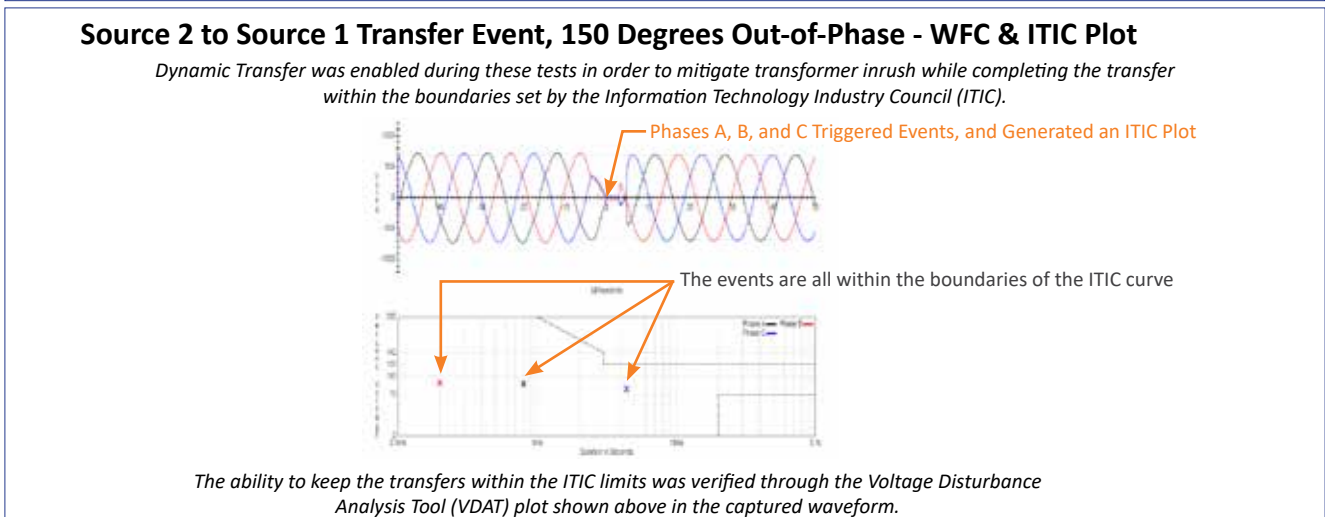
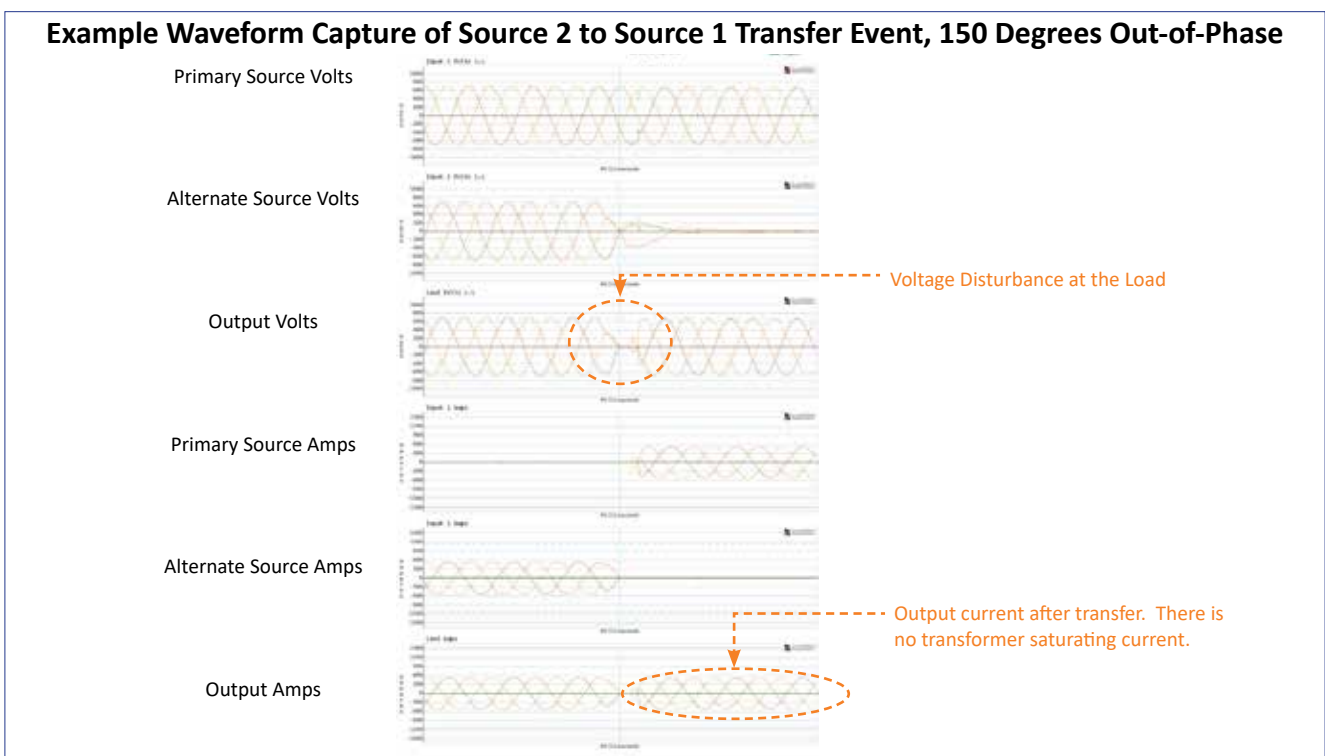

**Controls Section Contains:**

Control Electronics

- System Control & Data Acquisition Boards
- SCR Gate Drives
- Redundant Power Supply System
- I/O system; VPN Router

Power electronics

- SCRs (Silicon Control Rectifier) in Convection Cooled Heat Sinks

**CB Section Contains:**

- Input isolation switches
- Bypass isolation Switches
- Output isolation switches
- Source connection terminals
- Load connection terminals

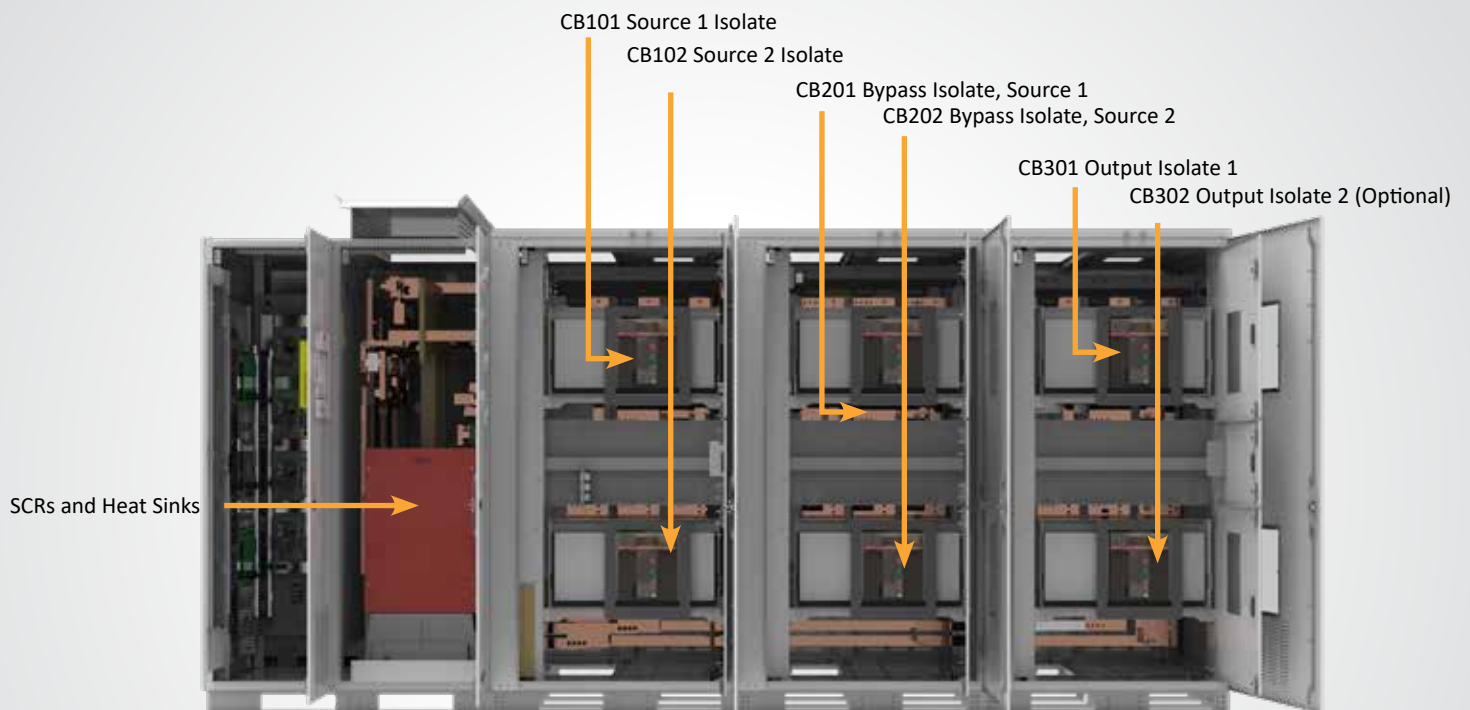

Reliability Overview

LayerZero eSTS Reliability Overview

The LayerZero eSTS Provides Many Dimensions of Reliability:

- Control System Reliability
  - SMR (Single Module Redundancy, Standard)
  - TMR (Triple Modular Redundancy, Optional)
- Control Power Supply Reliability
- Signal Reliability
- Operator Procedural Reliability



Single Module Redundancy (SMR) Reliability (Standard)

Single Module Redundancy is a cost-effective topology that provides redundant power paths to mission-critical equipment. In SMR systems, sources each have built-in triple redundancy of processors.

In addition, every phase is controlled with a separate gate drive board.

LayerZero Single Modular Redundant topology is unique that it the system is fail-safe, maintaining full switching functionality even if a critical board were to fail.

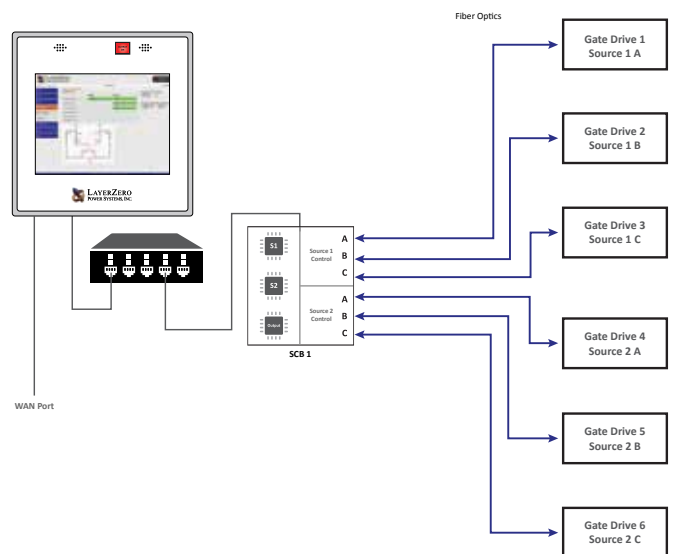

Reliability Features: Triple Modular Redundancy (TMR) \*Optional

**Triple Modular Redundancy (TMR) Reliability (Optional)**

LayerZero TMR has all the redundancy of SMR, plus each STS has three independent sets of analog and digital data acquisition and control systems. There is no direct communication between the three systems. The three systems do not even share a common system clock.

- Each control system acquires voltage and current data independently
- Each control system determines whether a source is good/bad independently
- Upon loss of a source, each control system makes decisions to transfer independently

Even if an entire control path or its subcomponent were to fail; and then if the active power source were to fail, the STS is able to complete its mission of transferring to the alternate source.

Triple Modular Redundancy, a proper noun, is based on proven statistics and stringent mathematics. There are similar sounding terms like, tri- or triple-redundant, used in industry to describe other STS products – but they simply do not yield the same, high level of reliability.

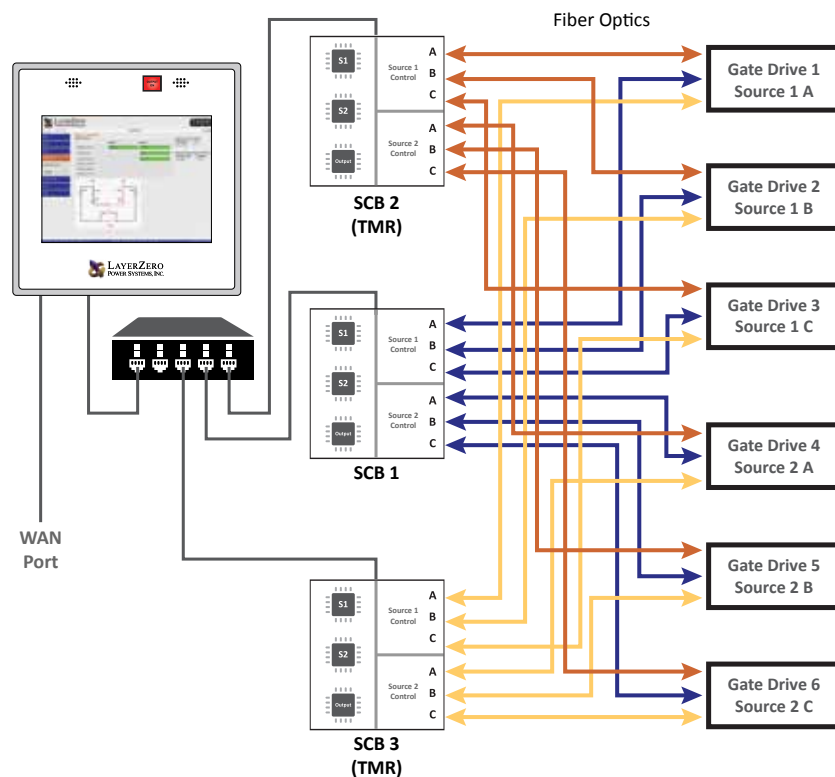

Reliability Features: Single Module Redundant (SMR) Redundancy

**eSTS SMR Triple Redundant Power Supply Architecture**

**Divided into four (4) logical failure groups:**

- System controls
- Source 1 gate drives
- Source 2 gate drives
- Peripherals.

The three (3) available source of power from which to supply control power to each failure group are:

- Source 1
- Source 2
- STS Output.

LayerZero’s STS design incorporates twelve (12) power supplies (3 power sources x 4 failure groups.) The resultant control power topology utilizes all possible power paths to the four logical STS failure groups; and is the most comprehensive and redundant power supply system in existence.

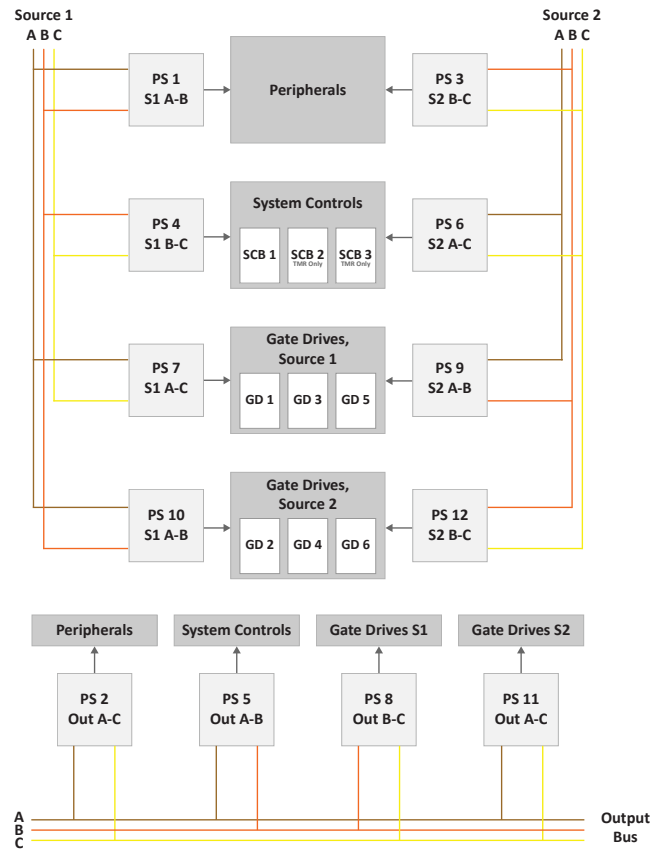

**eSTS SMR Triple Redundant Processors**

- Separate/independent processors for Source 1, Source 2 and Output power quality analysis
- If Source 1 processor malfunctions then system is able to be commanded to transfer to Source 2; & vice versa.
- If main control system fails then STS continues to conduct power to the load from the existing source of power. (However STS is unable to transfer to the other source)
- Each phase of each source is controlled with a separate gate drive circuit board.

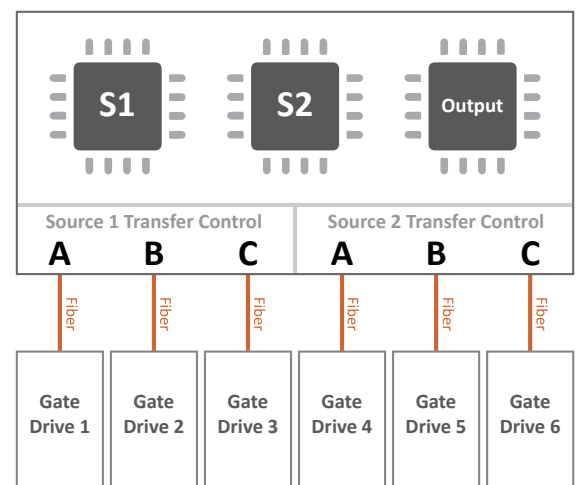



## Reliability Features

### Kirk Key Bypass Interlock

To minimize the possibility of operator error during equipment bypass operations, LayerZero provides:

1. Interlocked breakers
2. Mechanisms to ensure that a source cannot be bypassed without the STS on the correct source
3. Safeguards to make certain that sources cannot be connected to each other inadvertently
4. A Kirk key bypass interlock procedure that guides the operator through the sequence
5. A step-wise pictorial and video presentation on the touch-screen display during bypass



### Voice Guided Bypass

Operator error during maintenance bypass has been known to be a reliability hazard. To help prevent operators from completing the bypass procedure out-of-sequence, our product features a voice prompted bypass procedure. This instructs the operator in a step-by-step course of action of the process, with only one operation per screen. Visual and audio cues provide clear instructions on the bypassing sequence, reducing the probability of operator error.



### Silver Plating

LayerZero utilizes silver plating on all bus joints and terminals to be able to provide the highest performance. Silver has high conductivity and low resistance - which makes for a great contact.



## Reliability Features

### Machined Hardware

Our bolted connections utilize machined cap screws and engineered disc springs. The result is a flat pressure vs deflection profile to ensure that all bolted connections maintain constant torque through the life of the product.

These technologies have been well tested in disparate environments of wide temperature ranges to help ensure that, once connections have been tightened, they stay that way.



### Fiber Optic Controls Increase System Reliability

Fiber optic based controls eliminate noise and interference, while isolating components from high voltage. Optical fiber allows service to be reliably connected, while protecting the equipment. In LayerZero's eSTS design, the gate drives (at Power Circuit Voltage) receive control signals via optical fibers.

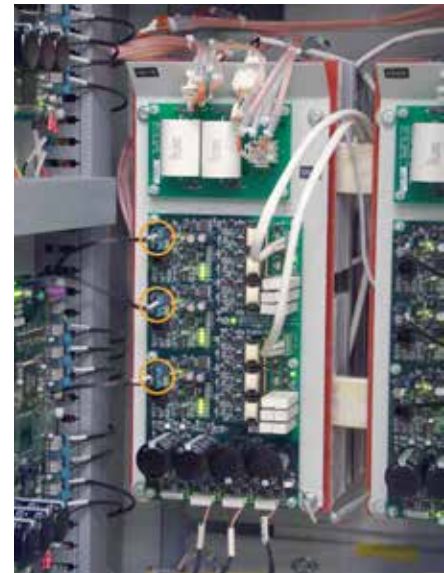

Safety - Ease of Maintenance

**INSIGHT™ IR Portholes Permit Scanning of Bolted Connections with Dead-Front Doors Closed**

Strategically positioned IR-scan portholes to enable safe thermal scanning of all bolted connections with the deadfront closed, without exposing the operator to power circuit voltage. Thermal scans can be done from the front – without ever having to open the dead-front door.

The IR window swivels upward and unlocks with key-hole access to reveal a mesh, allowing the operator to point-and-shoot thermal cameras to obtain readings.

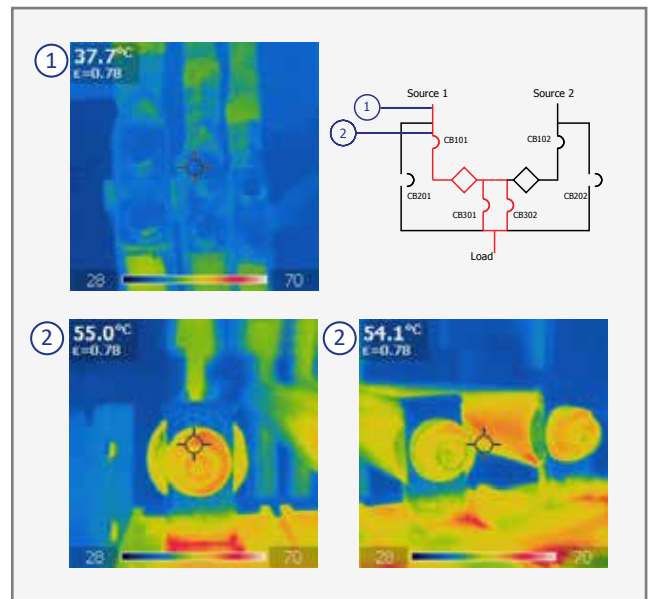

IR Portholes in eSTS  
(Door and side panel hidden for visibility)

Safety - Ease of Maintenance

**INSIGHT IR® Provides Early Detection of Thermal Issues**

INSIGHT IR® is a thermal monitoring system that is designed to continuously monitor the temperatures of critical components.

INSIGHT IR® captures data from a network of fixed infrared cameras, and displays a live image of the temperature of each connection.

INSIGHT IR® has the capability to view temperatures by-phase. If a problematic area is detected early, repairs can be made on equipment before the problem leads to downtime.



INSIGHT IR® live images can be viewed on a local or remote display.



INSIGHT IR® Camera Housing



INSIGHT IR® generates a hybrid heat map over a visible image

INSIGHT IR® Cameras are installed near bolted connections and critical components

Safety/Connectivity

**Sectionalization Maximizes Operator Safety**

Operators are well-protected from exposed connections. Normal operator sections (breakers/switches) are physically separated from the power electronics and control electronics sections, so that maintenance on a section can be safely performed. If maintenance is required on a particular section, power can be bypassed to another section to allow for safe repairs to be made.

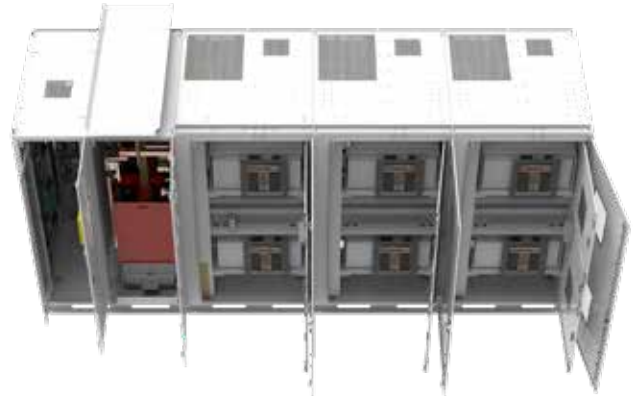

**eSTS Connectivity Options**

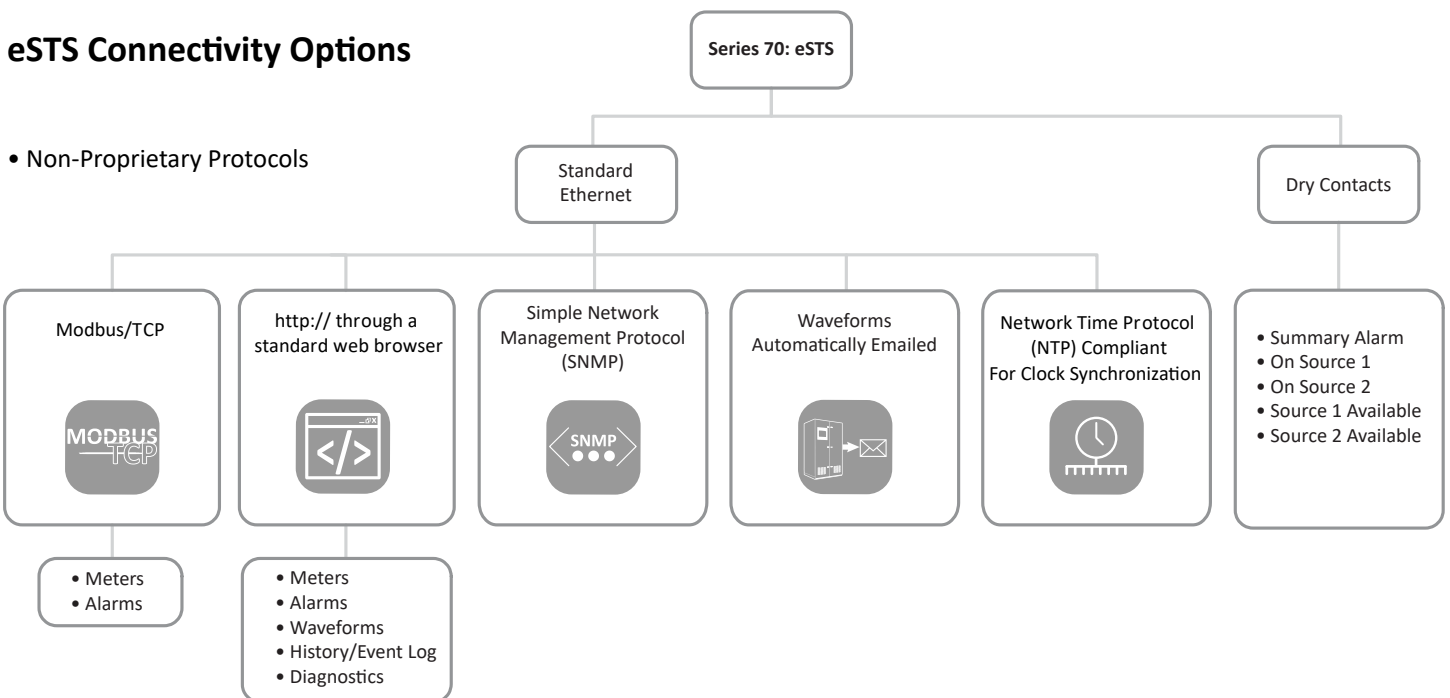

Features/Power Quality Monitoring

LayerZero Power Quality Monitoring

LayerZero PQM (Power Quality Monitoring) allows you to be aware of all activity in your critical power distribution systems, it is an all encompassing monitoring system with local and remote communications options. From basic monitoring, alarms, to advanced power quality monitoring functionality, LayerZero PQM provides a wide-range of options to help you maintain the highest level of reliability.

LayerZero PQM gives you a vendor-neutral “Birds Eye” view of your entire critical power distribution infrastructure. LayerZero PQM maximizes reliability, letting you know if a source has quality issues, if a UPS output is bad, or if there are any alarms. In addition, LayerZero PQM empowers users with the capability to go back in time to retrace the exact sequence of historical events. No other tool in the mission-critical industry empowers users with this robust capability.

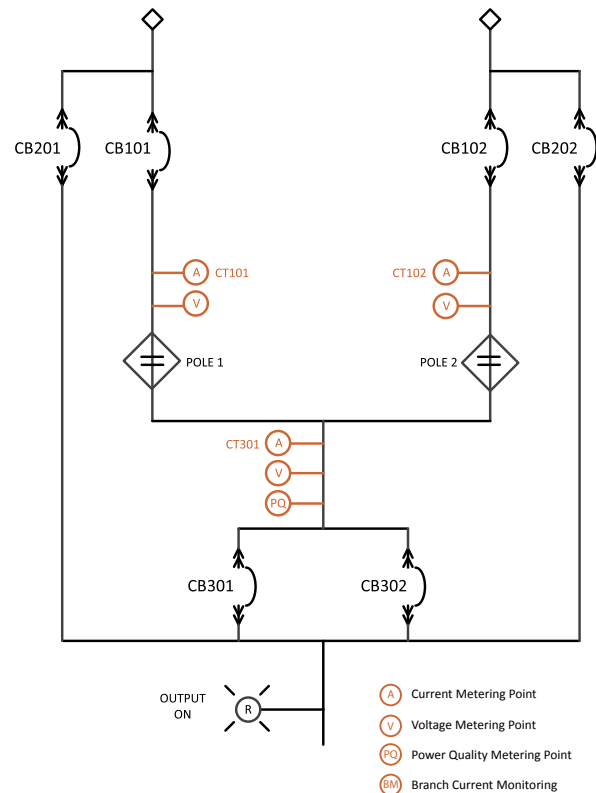

15" Color Touch Screen (Standard)

1. Stereo Speakers for Guided Bypass Prompts
2. Output On Light (Remains Lit in Bypass Isolate Mode)
3. Alarm & Bypass Indicator
4. SCB Status Indicator
5. Logged In User
6. Navigation Menu
7. Customer & Project Information
8. Date & Time

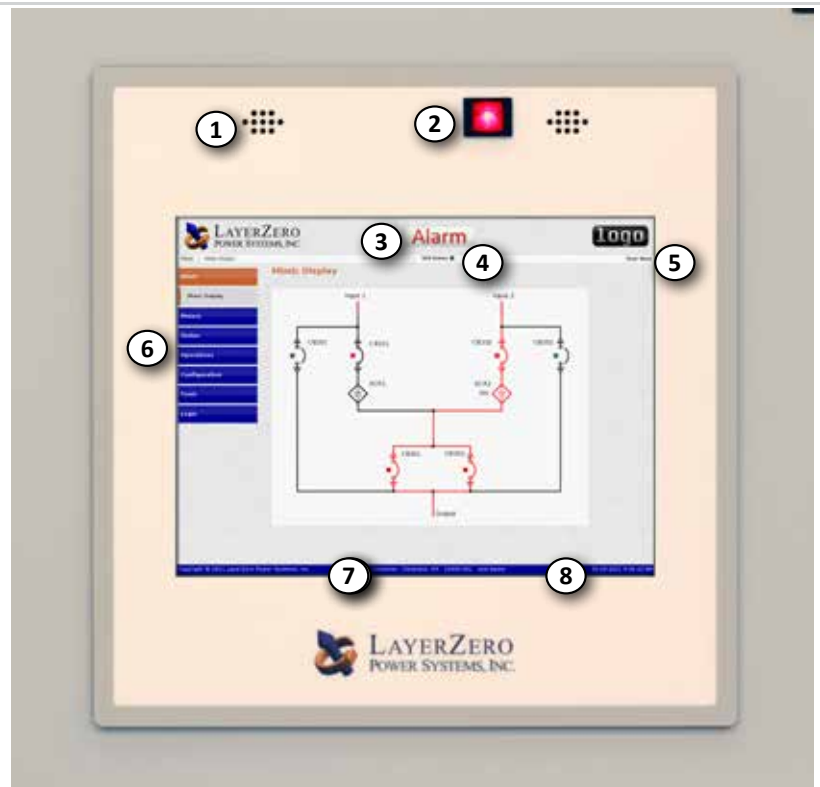

Power Quality Monitoring

Static Switch Power Quality Monitoring

The Series 70: eSTS is equipped with LayerZero SSQM (Static Switch Quality Monitoring), an all encompassing monitoring system with local and remote communications options.

From basic monitoring & alarm reporting, to advanced power quality monitoring functionality, LayerZero’s SSQM provides a wide-range of options to help you be aware, be vigilant, be proactive in your quest to create a safe, stable and reliable operation.



LayerZero’s SSQM Provides Answers

LayerZero SSQM provides timestamped pictures of waveforms before and after events, providing information that enables facilities to go back in time to methodically identify and correct the root causes of events. LayerZero actively captures power quality information at the STS, PDU, and RPP - permitting thorough post-event analysis.

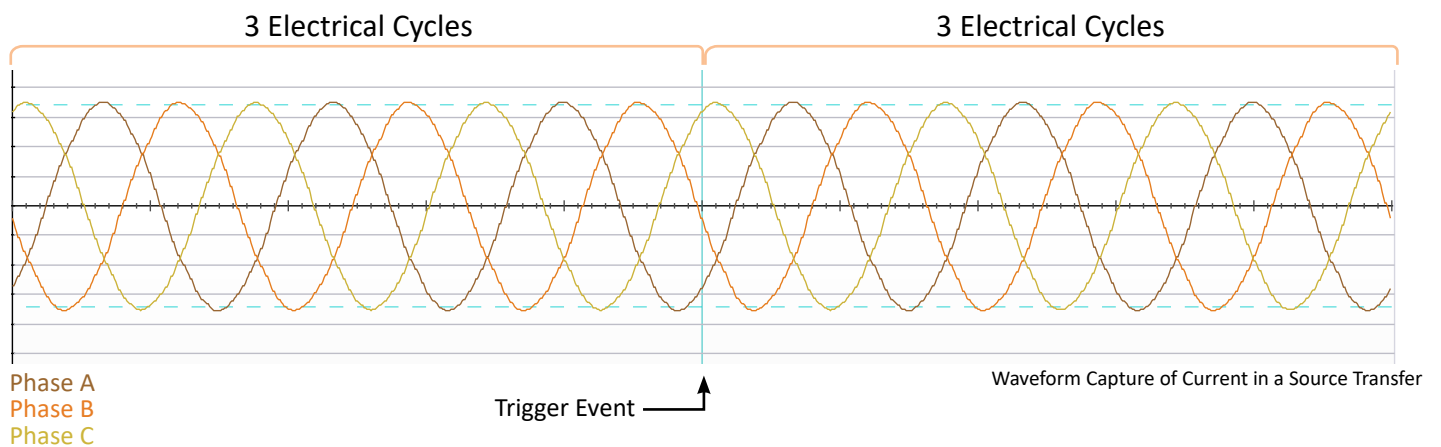

## LayerZero SSQM Technical Specifications

LayerZero SSQM Parameters		Mains
<b>Voltage Inputs and Output</b>	Voltage (Volts)	✓
	Voltage Average of Phases (Volts)	✓
	Frequency (Hertz)	✓
	Total Harmonic Distortion (Percent VTHD)	✓
	Phase Rotation	✓
<b>Current Inputs</b>	Current (Amps)	✓
	Current Average of Phases (Amps)	✓
	Current Imbalance (Percent)	✓
	Real Power (kilowatts)	✓
	Apparent Power (kilovolt-amperes)	✓
	Reactive Power (kilovolt-amperes reactive)	✓
	Power Factor	✓
	Crest Factor	✓
	Crest Factor Average of Phases	✓
	Phase Difference Between Sources	✓
	Phase Difference Between Sources and Output	✓
<b>Alarms</b>	Summary Alarm	✓
	On Source (1/2/3)	✓
	Source Fail (1/2/3)	✓
	Source Preferred (1/2/3)	✓
	Source 1st Alternate (1/2/3)	✓
	Source Over/Under Voltage (1/2/3)	✓
	Source Over/Under Frequency (1/2/3)	✓
	Source Not Available (1/2/3)	✓
	Output Failure	✓
	Source Overcurrent (1/2/3)	✓
	Source Exceeds Manual Limit (1/2/3)	✓
	Source Exceeds Automatic Limit (1/2/3)	✓
	Bypassed to Source (1/2/3)	✓



## Technical Specifications: 3-Pole Static Transfer Switch

Mechanical Characteristics *	
Current/Voltage/Number of Poles	3000 A 480 V 3-Pole
Heat Dissipation	Please contact LayerZero engineering
Weight	11,200 lbs [5080kg]
Dimensions	89" x 192" x 57" (2263 mm x 4883 mm x 1448 mm)
Clearances	FRONT: 42 IN. [1067] REAR: 42 IN. [1067] SIDES: 4 IN. [101] TOP: 18IN. [457]
Frame Construction	Welded Frame
Electrical Connections	Silver-Plated Solid Busbar
Color	Textured Powder Coat White (RAL 7035), Blue (RAL 5017), Black, Custom
Floor Stands	Optional
Seismic floor stands	Optional
Junction Boxes	Optional
Sectionalization	Engineered Composite Insulation, Dead Front Doors
Electrical Characteristics	
Number of Inputs	2, 3 (3 optional)
Number of Output CBs	1, 2
Frequency	50 Hz, 60 Hz
Poles	3-pole
Phases	3 Phase, 3 Wire, 4 Wire + Ground
Neutral Rating	100%, 150%, 200%
Transfer Time	Nominal 1/4- cycle for in-phase sources
Redundancy	Single Module Redundancy, Triple Modular Redundancy (Optional)
Circuit Breaker Type	Molded Case Switch (Standard), Electronic Trip (Optional)
Circuit Breaker Mounting Type	Plug-In up through 600 A; Draw-out 800 A, 1200 A
TVSS	Standard
Power Quality Monitoring	
Power Quality Monitoring Technology	LayerZero PQM (Static Switch Quality Monitoring)
Waveform Capture	Local Display, Remote Display via Web Browser, Waveforms Automatically Emailed
Voltmeter	Input sources and Output, for each phase
Ammeter	Input sources and Output, for each phase
Frequency Meter	Both Sources
Synchroscope	Phase Angle Meter Between Sources
Metering	Apparent Power, Real Power, Power Factor, Output Total Harmonic Distortion
Time Stamped Transfer Count	From First Day Use, From Last Reset
CB Status Indicator	Open/Closed/Tripped Circuit Breaker
Source Indicator	Preferred Source
Power Path Indicator	On Live Mimic

\*Dimensional &amp; weight data is only valid for 2-source.

All product specifications are subject to change without notice.

## Technical Specifications

Operational Characteristics	
Transfer Modes	Automatic; Manual (via Preferred Source Selection)
Inrush Mitigation Technology	Patented Dynamic Phase Compensation Algorithm (U.S. Patent 7,589,438 B2)
Cooling	Convection Cooling
Cable Access	Top/Bottom
Service Access	Front Only
Bypass Interlock Mechanism	Mechanical
Noise & Interference Isolation	Optical Fiber in Critical Control Paths
IR Scan Port Type	INSIGHT™ IR Portholes
SCR Type	Puck
Display Type	15" Color Touch Screen
Display Resolution	1024x768
Bypass Assistance	Voice-Guided Bypass
Audio	Bezel-Mounted Stereo Speakers
Languages	English, French
Mimic Panel	Digital
Setpoints Control	Digital
Power Supplies	Redundant (4 Failure Groups. Triple Redundant Supplies. 12 Power Supplies Provided.)
Connectivity	
Meters	Local Display, Ethernet, Modbus/TCP, http via Web Browser (Non-Proprietary)
Alarms	Local Display, Ethernet, Modbus/TCP, http via Web Browser (Non-Proprietary)
Summary Alarm	Dry Contacts; Local Display; Modbus/TCP; Web Browser
Waveforms	Local Display, Ethernet, http via Web Browser (Non-Proprietary)
History/Event Log	Local Display, Ethernet, http via Web Browser (Non-Proprietary)
Diagnostics	Local Display, Ethernet, http via Web Browser (Non-Proprietary)
Time Synchronization	Network Time Protocol (NTP)
Standards Conformance	
CSA	ETL Listed to C22.22 No 107.
UL	ETL Listed to UL 1008S

All data tables above are for 3-pole only. Contact LayerZero for custom sizes and designs.

All product specifications are subject to change without notice.

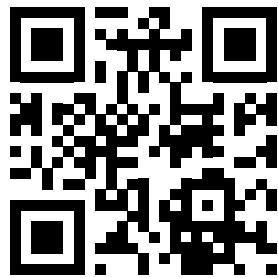

Learn more at [www.LayerZero.com](http://www.LayerZero.com)



LayerZero Power Systems, Inc.  
1500 Danner Drive  
Aurora, OH 44202 U.S.A.

© 2023 LayerZero Power Systems, Inc.

[LayerZero](#)®, INSIGHT IR®, SAFEARM®, SAFEPANEL®, and LayerZero Power Systems, Inc.® are registered trademarks of LayerZero Power Systems, Inc. All Rights Reserved.

All product specifications are subject to change without notice.

Rev. 11/23 #10